

PRODUCT SPECIFICATIONS

DESCRIPTION

The STAGECRAFT 300 Series Compact Track System is ideal for studio and other commercial applications where a low profile, smooth running tracking is required.

The system may be operated via:

- Walk-along,
- Manual hauling line
- Motor driven

The 300 Series Compact Track System is designed to install directly to, and be continuously supported by an existing structure.

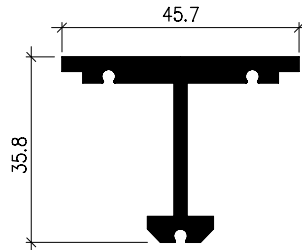

Section of Track

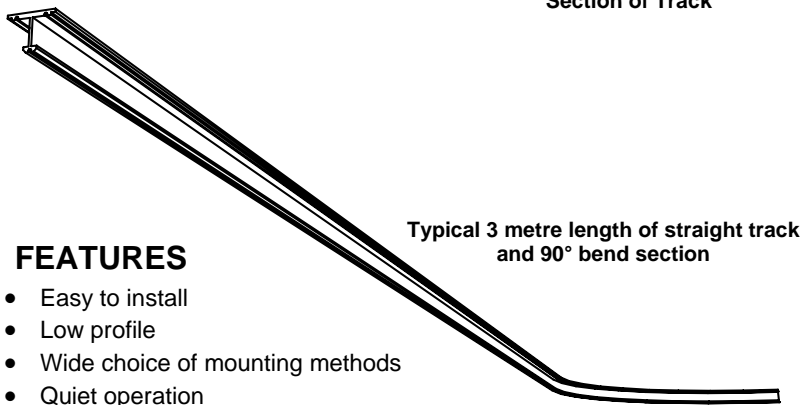

Typical 3 metre length of straight track and 90° bend section

FEATURES

- Easy to install
- Low profile
- Wide choice of mounting methods
- Quiet operation
- Finish—Hard wearing Black powder-coat
- 90° corners standard, other angles available to order
- Corners from 300 mm radius
- Standard track lengths 6 metres, other lengths to order
- Special mounting and custom layouts available.

Selected Components & Accessories

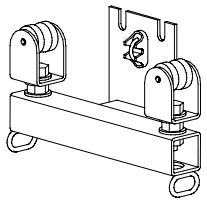
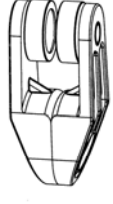
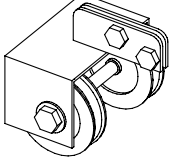
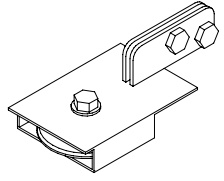
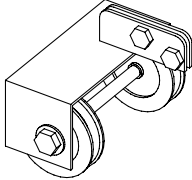
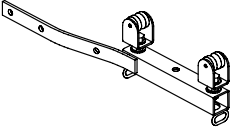
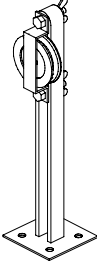
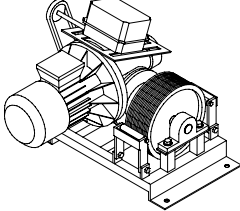
 200MC1 Master carrier	 200SC2 Single Carrier
 300HP1 Head Pulley	 300RP Return Pulley
 300HP2 Head Pulley— Overlapped track	 200MC2 Master Carrier— Cranked Arm
 100FP Floor Mounted Adjustable Pulley	 100MD55 Three Phase .55kw Motor Drive

Architectural Specification

The track shall be a black anodized extruded aluminum STAGECRAFT Compact Track System providing silent and smooth operation.

It shall be capable of top mounting anywhere along its length. Individual runners shall be bearing loaded nylon wheeled type and spaced at nominal 250 mm centres. Runners shall be rated at 30 kg each maximum. It shall be possible to remove or replace any runner anywhere along the track.

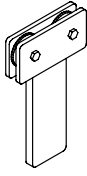
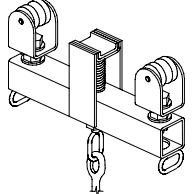
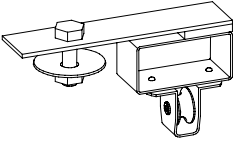
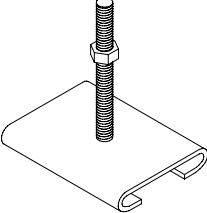
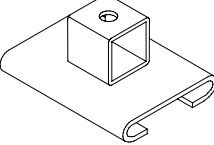
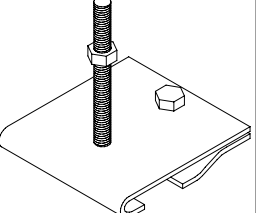
 100WP Weighted Floor Pulley	 200MC3 Master Carrier with Brake	 200OG Outside Line Guide
 200 TF1 Top Fix Clamp 8 mm Stud	 200TF2 Top Fix Clamp - Mounting Block	 200TF3 Top Fix Clamp - 2 Piece with Stud