

stagecraft
Pty Ltd

**ENTERTAINMENT
ENGINEERING**

Stub Hub Pile winding Winch

PRODUCT SPECIFICATIONS

DESCRIPTION

STAGECRAFT Stub Hub Pile winding Winches are designed to provide powered lifting mechanism for lighting bars and other tasks in theatres and studios where inexpensive single-speed hoisting of up to 12 metres is required, and where space is limited.

FEATURES

- Engineered to a high standard
- Upper and lower limit automatic stop mechanism - standard.
- Self-sustaining gearbox
- Optional orientation of motor, drum & gearbox
- Brake motor range — .75 kW
1.1 kW
1.5 kW
2.2 kW
3.0 kW
- Many mounting options available
- Multi-cable drums configured to each project's requirements.

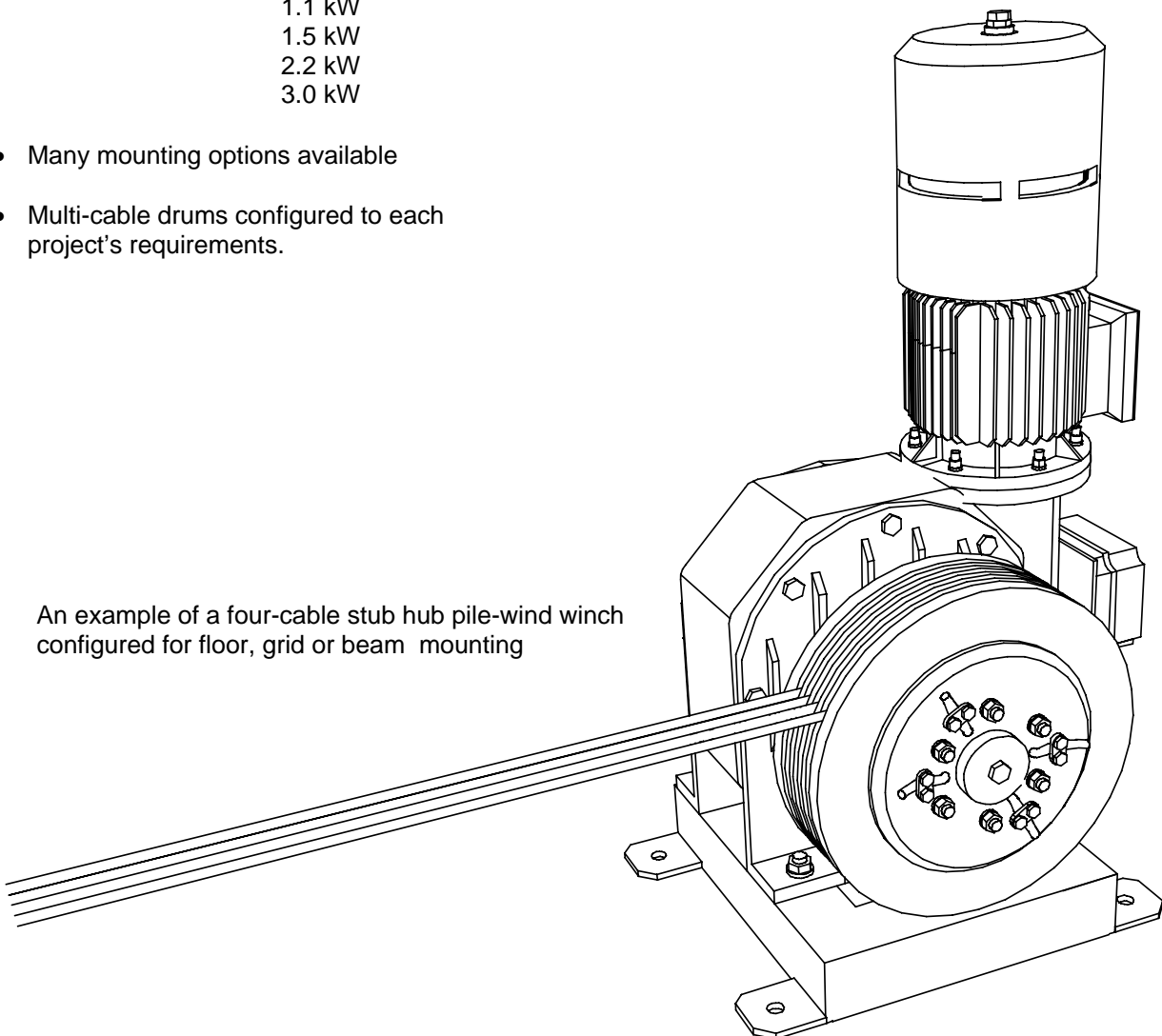

An example of a four-cable stub hub pile-wind winch configured for floor, grid or beam mounting

SC/KR 019 -4/06

STAGECRAFT PTY LTD, ABN 11 009 040 144
11 INVERNESS STREET, MALAGA, WESTERN AUSTRALIA 6090
PHONE +61 8 9249 2700 FAX +61 8 9249 2709
www.stagecraft.com.au

All specifications may be changed without prior notice. While due diligence is used in compiling the data herein, Stagecraft Pty Ltd does not accept liability for losses ensuing from any errors or omissions.